

Accurate Channel Sounding with a Phase Stabilizing Scheme

Wei Fan⁽¹⁾, Allan Wainaina Mbugua⁽¹⁾, and Kim Olesen⁽¹⁾

(1) Antenna Propagation and Millimeter-wave Systems (APMS) section, Department of Electronic Systems, Faculty of Engineering and Science, Aalborg University, 9220 Aalborg, Denmark

Abstract

Coaxial cables are vital to a wide range of electronic systems. Phase accuracy in coaxial cables is sensitive to the inevitable cable bending in actual usage and temperature change in the environment. For phase-critical applications, e.g. multi-antenna channel sounding, phase accuracy is fundamental to obtain trustworthy measurement results. A technique to track and remove random phase change in coaxial cables due to cable effect is presented. The phase-stabilizing technique provides a general phase stabilizing framework via introducing a bi-directional transmission on the cable. The principle of the phase stabilizing scheme is explained and its effectiveness is experimentally validated in a back-to-back measurement.

Index terms— Channel sounding, phase accuracy, coaxial cables, phase stabilizing.

1 Introduction

Electronic systems have become increasingly sensitive to phase changes in their components, and cables can be a significant source of poor phase performance [1]. Ideally, cables are utilized to transfer radio signals from one location to another, without affecting (i.e. electrically invisible to) the transferred signals. In practical usage cases, however, cables are expected to undergo frequent bending, which can result in significant phase changes, depending on the bending radius and types of cables [1]. Another major source of phase change in cables is the temperature change in the environment [1, 2]. Phase stability is crucial in some phase critical applications, e.g. frequency distribution system [3], radio interferometry [4], channel sounding [5, 6, 7, 8]. In [4], the ultra-stable phase stability is achieved by configuring a closed phase-locked loop with a single-mode optical fiber transmission line. It was further described in [2] that design, materials and processes should be considered simultaneously to obtain good phase performance. Understanding the properties of the of radio channels is key to the design of wireless systems, which necessitates reliable channel sounding in the deployment scenarios [5, 6, 7, 8]. Phase accuracy is important in channel sounding, since angle of arrival estimation of multipath components relies on the phase relationship between antenna array elements. Synchronization between the transmitter (Tx) and receiver

(Rx) is mandatory in channel sounding to obtain accurate phase and time of flight information. High stability clocks are often used for synchronization at the Tx and Rx side [7]. Vector network analyzer (VNA) has been an attractive alternative channel sounder in the literature [5, 7, 8], where coaxial cables are used to carry radio signals, remote antennas, and achieve phase synchronization. Virtual antenna array concept, where a large-scale virtual array is formed via mechanically placing a single antenna in different pre-defined measurement locations (i.e. array elements), is widely adopted in VNA based channel sounders due to its simplicity, flexibility and cost efficiency [8]. For phase-critical applications, e.g. channel sounding, it is vital to avoid phase randomness caused by cables. It is important to combat cable bending and temperature change and ensure accurate phase measurements.

In this paper, a phase stabilization scheme is presented for the VNA based channel sounders, which can effectively remove the random and unpredictable phase behaviour in the coaxial cable via utilizing a feedback link. To the best of our knowledge, the presented method has not been reported so far.

2 Problem Statement

As illustrated in Fig. 1(a), VNA is an intrinsic channel sounder where channel frequency response (which includes the antenna response and propagation channel) can be recorded in $S_{21}(f)$ in the S-parameter test set as

$$S_{21}(f) = h_{cable}(f)h_{12}(f) \quad (1)$$

where $h_{cable}(f)$ and $h_{12}(f)$ denote frequency responses of the cable and radio channel, respectively. $h_{cable}(f)$ is typically calibrated out (i.e. $h_{cable}(f) = 1$) in the back-to-back measurement. As explained earlier, radio signals might be affected by the coaxial cables due to cable bending and temperature change in the environment. We can introduce a term $\Delta h_c(f)$ to denote signal change in the cable. After calibration, we have,

$$S_{21}(f) = \Delta h_c(f)h_{12}(f) \quad (2)$$

Therefore, $\Delta h_c(f)$ is embedded in the measured frequency response and difficult to remove since it is random and unknown in practice.

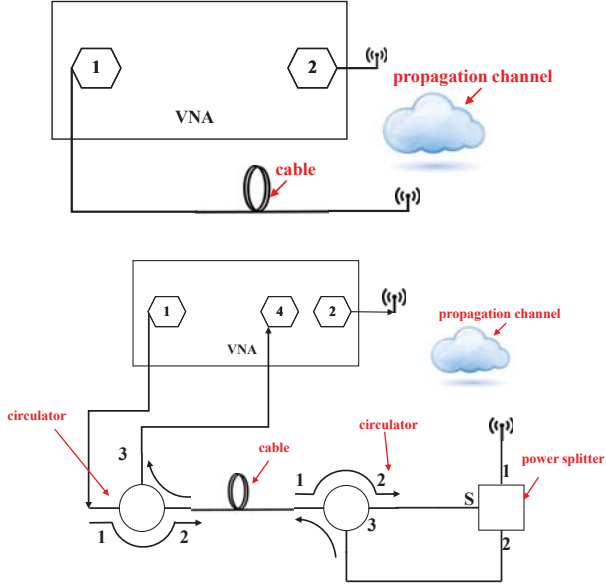

Figure 1. VNA based channel sounder. (a) Original setup; (b) Phase-stabilizing setup with phase tracking and correcting scheme.

3 Phase-stabilizing Method

The phase-stabilizing setup is illustrated in Fig. 1(b), where a forward link and a feedback link are implemented on the same cable (i.e. bi-directional transmission) based on circulators and a splitter. $S_{21}(f)$ of the forward link can be written as:

$$S_{21}(f) = h_{FW}(f)\Delta h_c(f)h_{12}(f) \quad (3)$$

where $h_{FW}(f)$ denotes the frequency response of the forward link, which characterizes the effect of the cables, two circulators, and the power splitter. $S_{41}(f)$ of the feedback link can be denoted as:

$$S_{41}(f) = h_{FB}(f)\Delta h_c(f)^2 \quad (4)$$

where $h_{FB}(f)$ denotes the frequency response of the feedback link. Note that we have $\Delta h_c(f)^2$ in (4) and $\Delta h_c(f)$ in (3) since the signal travels once in the forward link yet twice in the feedback link. Again, both $h_{FW}(f)$ and $h_{FB}(f)$ can be calibrated out in the back-to-back measurements first (i.e. $h_{FW}(f) = h_{FB}(f) = 1$). Therefore, we have

$$h_{12}(f) = \frac{S_{21}(f)}{\sqrt{S_{41}(f)}} \quad (5)$$

The basic principle of the phase-stabilizing method is that the random and unpredictable phase behaviour in the coaxial cable can be measured and then de-embedded once a bi-directional transmission on the cable is achieved using circulators and power splitter. The phase stabilization scheme helps to avoid undesired phase changes in the coaxial cable effectively.

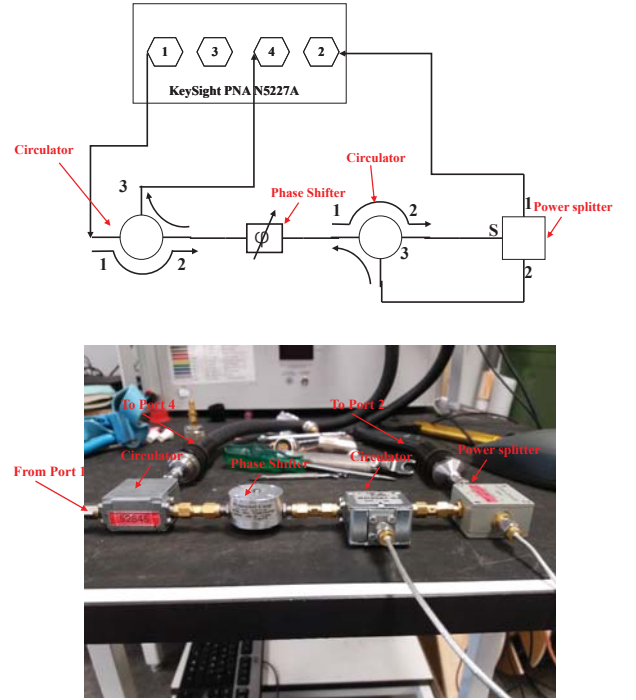

Figure 2. Validation measurement. (a) Illustration of the back-to-back measurement setup; (b) Photo of the practical measurement setup.

4 Validation Measurements

The phase-stabilizing method is experimentally validated in a back-to-back measurement as illustrated in Fig. 2(a). A mechanical phase shifter is used to mimic the possible phase change in the coaxial cable due to temperature change or cable bending. The phase in the phase shifter is recorded at 1.6 GHz with a frequency span of 450 MHz (from 1.55 GHz to 2 GHz) and a frequency step of 2.5 MHz. For each phase value set in the phase shifter, we recorded the forward link frequency response $S_{21}(f)$ and the feedback link frequency response $S_{41}(f)$ with the VNA. A photo of the measurement setup is shown in Fig 2(b).

In the measurement, we first set the mechanical phase shifter to 0 degrees (denoting no phase change in the cable) and then we measured and stored $S_{21}(f)$ and $S_{41}(f)$ for the back-to-back calibration. The measured phases with 0 degree set in the phase shifter after calibration are shown in Fig. 3(a) and Fig. 3(b), respectively, for the forward link and the feedback link. After the back-to-back calibration, a maximum phase error of around 1 degree for the forward link and 2 degrees for the feedback link can be observed, indicating an effective back-to-back calibration process. Then, the phase shifters were set to three other values, i.e. 15 degrees, 20 degrees, and 45 degrees, to mimic three different phase changes introduced by the cable effects. The phase responses over frequency of the forward link and the feedback link are shown in Fig. 3(a) and Fig. 3(b), respectively. As shown in Fig. 3(a), the phases recorded at 1.6 GHz in the forward link correspond well to the pre-set

values, with a maximum deviation of around 2.5 degrees. The frequency response of the phase shifter is not linear over the swept frequency in the measurement. As shown in Fig. 3(b), the measured phase response over frequency of the feedback link is always approximately twice that of the forward link, as expected. The compensated frequency responses with different phase values set in the phase shifters, adopting (4), are shown in Fig. 3(c). The achieved phase error is less than 2 degrees at the specified 1.6 GHz with the proposed method, regardless of the phase values set in the phase shifters. Over the measured 450 MHz span, the achieved phase error is around within ± 4 degrees although the frequency response of the phase shifter is non-linear, indicating an excellent achieved phase stability.

5 Conclusion

This paper presents a phase-stabilizing technique for coaxial cable to achieve accurate radio channel sounding. The phase-stabilizing method ensures that the measurement is immune to stochastic phase changes in the coaxial cable due to cable bending or temperature change. The phase-stabilizing setup is further experimentally validated in a back-to-back measurement, where its phase stabilizing capability is demonstrated in the measurement.

References

- [1] Mini-Circuits, "More than just a phase: understanding phase stability in RF test cables," <https://ww2.minicircuits.com/app/AN46-004.pdf>, accessed October, 2018.
- [2] Times Microwave Systems, "Current innovations in phase stable coaxial cable design," <https://www.timesmicrowave.com>, accessed October, 2018.
- [3] K. Sato et al., "Application of phase-stabilized optical fiber in transmission of reference and IF signals in VLBI observation," in *IEEE Transactions on Instrumentation and Measurement*, vol. 41, no. 3, pp. 385-389, June 1992.
- [4] K. Sato, T. Hara, S. Kuji, K. Asari, M. Nishio and N. Kawano, "Development of an ultrastable fiber optic frequency distribution system using an optical delay control module [for frequency standard and VLBI]," in *IEEE Transactions on Instrumentation and Measurement*, vol. 49, no. 1, pp. 19-24, Feb. 2000.
- [5] J. Molina-Garcia-Pardo, J. Rodriguez and L. Juan-Llacer, "MIMO Channel Sounder Based on Two Network Analyzers," in *IEEE Transactions on Instrumentation and Measurement*, vol. 57, no. 9, pp. 2052-2058, Sept. 2008.
- [6] L. Talbi and J. LeBel, "Broadband 60 GHz Sounder for Propagation Channel Measurements Over Short/Medium Distances," in *IEEE Transactions on*

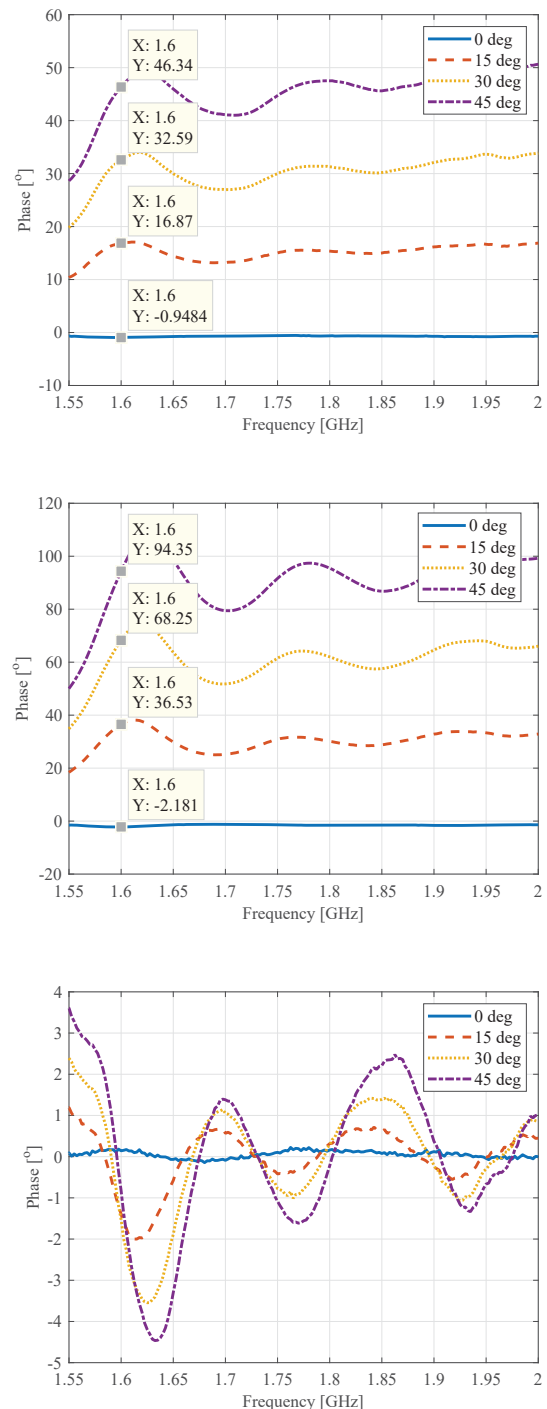

Figure 3. Measured phase responses over frequency at different phase values set in the phase shifters. (a) Forward link; (b) Feedback link; (c) Corrected phase response.

Instrumentation and Measurement, vol. 63, no. 2, pp. 343-351, Feb. 2014.

- [7] G. R. MacCartney and T. S. Rappaport, "A flexible millimeter-wave channel sounder with absolute timing," *IEEE J. Sel. Area Comm.*, vol. 35, no. 6, pp. 1402-1418, June 2017. doi: 10.1109/JSAC.2017.2687838.
- [8] W. Fan, I. Carton, J. Nilesen, K. Olesen, and G. Pedersen, "Measured wideband characteristics of indoor channels at centimetric and millimetric bands", *EURASIP J. Wirel. Comm.*, 2016, no. 1, pp. 58, doi: 10.1186/s13638-016-0548-x.