

A Wideband 60 GHz VCO with Linear Tuning Range

Qiong Zou, Kaixue Ma, and Kiat Seng Yeo

School of Electrical and Electronic Engineering, Nanyang Technological University

50 Nanyang Avenue 639798, Singapore

zouqiong@ntu.edu.sg

Abstract

A wideband 60 GHz VCO with linear tuning range is proposed in this paper. The transformer-based differential tuning scheme is proposed for the fine frequency tuning, and the varactor pairs are used for the coarse frequency tuning. The VCO demonstrated 22.2 % tuning range from 56.43 to 69.79 GHz. By using the differentially tuned scheme, the proposed VCO has a linear tuning range, which can be used in wide band frequency synthesizer where a constant loop gain is desired.

1. Introduction

Currently, the wide tuning range and low phase noise VCO for the unlicensed frequency band around in 60 GHz is a challenging topic. The conventional tuning method using single varactor to cover the whole tuning range is not practical for 60 GHz application. For one reason, the quality factor of large size varactor is extremely low at 60 GHz, so the phase noise will be degraded [1]. For another, the VCO gain (K_{vco}) would be large, which will increase AM-to-FM noise [2]. The coarse frequency tuning method using switched capacitors or switched inductors can reduce the K_{vco} . However, the switch connected to tank will decrease the tank Q [3].

In this work, a wideband VCO with triple-coils transformer is proposed. The varactor pairs are used for coarse frequency tuning instead of switched capacitors to avoid switch loss and parasitics. The differentially tuning scheme using PMOS and NMOS varactor is applied to get a constant loop gain of VCO. The tuning range of VCO is 13.36 GHz from 56.43 to 69.79 GHz, which can fulfill the 60 GHz unlicensed frequency band.

2. VCO circuit design

Figure 1 shows the schematic of proposed VCO, where a triple-coil transformer is used. L_p , L_s , and L_T are the self-inductance of triple-coil transformer. The NMOS Transistor M1 and M2 form the cross-coupled pair to provide the negative resistance for oscillation. Two sets of varactors pair C_{p1} , C_{p2} are connected to the primary coil of transformer, and C_{s1} , C_{s2} are connected to the secondary coil of transformer. Usually, the bias-Tee circuit is required in between the buffer stage and VCO core to provide separate bias voltage of buffer stage and enough isolation of VCO core from buffer [4]. However, in mm-wave, the additional bias circuit would consume large chip area and also bring parasitics to the VCO core, so that degrade the VCO performance. In this work, the differential outputs of VCO are extracted to the two common source buffers by the third coil of transformer. Because of the nature characteristic of transformer, the dc voltage of VCO core is decoupled, while the ac signal is coupled to the buffer stage. The bias voltage of buffer can be applied through the center tap of the third coil, so no additional RF choke is needed for the buffer.

The operation frequency bands of VCO are controlled by the voltage signal SW. When “SW” is 0, the VCO will operate at high frequency band (HFB), when “SW” is 1.2 V, the VCO will operate at low frequency band (LFB). For each frequency band, the differentially fine tuning is provided by NMOS varactor C_{p2} and PMOS varactor C_{s2} . The tuning voltage of C_{p2} and C_{s2} are V_n and V_p respectively. During the fine tuning, V_n is increased from 0 to 1.2 V, while $V_n + V_p$ is kept as constant.

Figure 2. shows the structure of triple-coils transformer. The transformer is implemented with 9 metal layers, the L_p and L_s are concentric coupled and built with the second top layer, which has the largest thickness. L_T are made with top metal and placed above the L_p and L_s . The transformer is optimized by EM simulation to keep compact size and minimize the parasitics. The outer dimension of transformer is 90 μm , the width of metal trace is 9 μm . Figure 3 plots the simulated inductance and Quality factor of transformer. The simulated self-inductance L_p , L_s and L_T are 93.3 pH,

88.2 pH, and 96.8 pH, respectively at the frequency of interested. The quality factor of L_p , L_s and L_T are 17, 15 pH, and 14 pH, respectively.

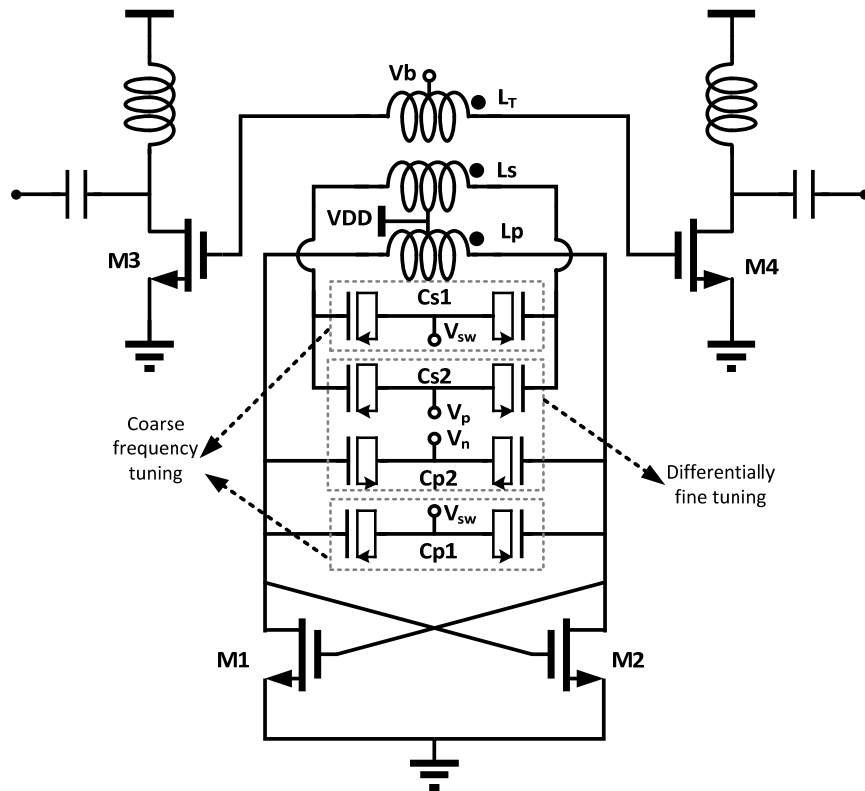

Figure 1. Schematic of proposed VCO

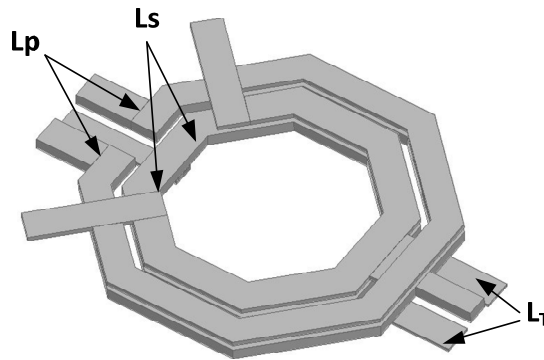

Figure 2. Structure of triple-coil transformer

3. Simulation Results

The proposed VCO is designed and implemented in 65nm CMOS process. With the supply voltage at 0.8 V, the proposed VCO core consumes 7.6 mA DC current. The buffers dissipate 7.63 mW DC power from a 1.2 V supply voltage. The oscillation frequency of VCO is controlled by V_n and V_p simultaneously. During the tuning, V_n+V_p is kept as constant. Figure 4 shows the frequency tuning curves for different V_n+V_p values. The linearity of frequency versus tuning voltage is improved when V_n+V_p is decreased from 1.2 V to 0.9 V. For $V_n+V_p=0.9$, the VCO has a tuning range of 13.36 GHz with the low frequency band from 56.43 to 62.42 GHz and the high frequency band from

62.45 to 69.79 GHz. Figure 5 present the phase noise of VCO when $V_n+V_p=0.9$ over the whole tuning range at 1MHz offset from the carrier frequency. The phase noise for low frequency band is from -95.5 to -100.7 dBc/Hz, and is -99.5 to -96 dBc/Hz for high frequency band. The best phase noise for low frequency band and high frequency band is presented in Figure 6.

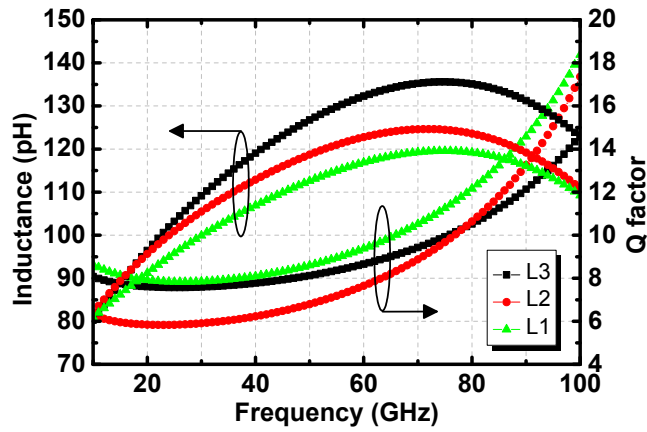

Figure 3. Simulated inductance and Q factor of transformer

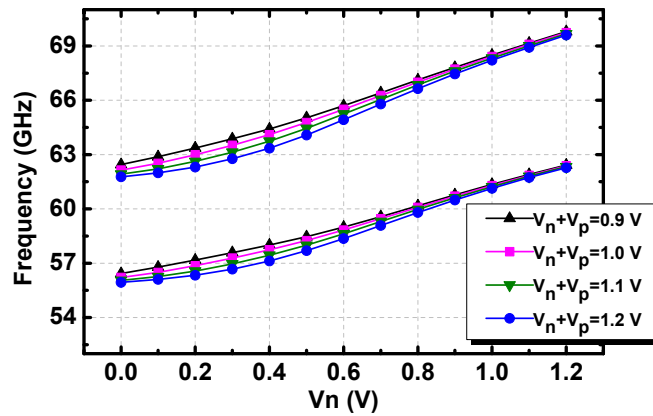

Figure 4. Oscillation frequency with the tuning voltage.

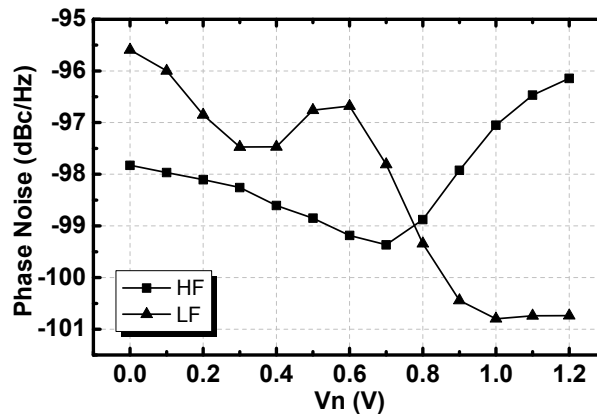

Figure 5. Phase noise at 1MHz offset versus tuning voltage.

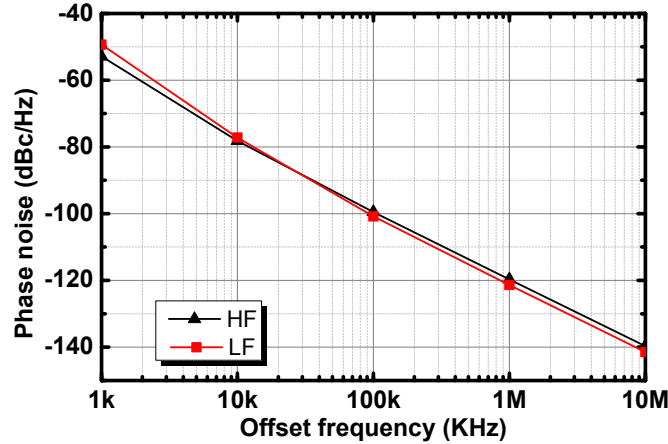

Figure 6. Phase noise versus the offset frequency.

4. Conclusion

In this paper, a 60 GHz wideband VCO with linear tuning range is presented. A triple-coils transformer is used in the circuit. With the supply voltage at 0.8 V, the proposed VCO core consumes 7.6 mA DC current. The tuning range of VCO is 13.36 GHz from 56.43 to 69.79 GHz, which can fulfill the 60 GHz unlicensed frequency band. The phase noise for low frequency band is from -95.5 to -100.7 dBc/Hz, and is -99.5 to -96 dBc/Hz for high frequency band.

5. References

1. Q. Wu, S. Elabd, J. J. McCue, and W. Khalil, "Analytical and experimental study of tuning range limitation in mm-wave CMOS LC-VCOs," in *Circuits and Systems (ISCAS), 2013 IEEE International Symposium on*, 2013, pp. 2468-2471.
2. E. Hegazi and A. A. Abidi, "Varactor characteristics, oscillator tuning curves, and AM-FM conversion," *Solid-State Circuits, IEEE Journal of*, vol. 38, pp. 1033-1039, 2003.
3. J. Yin and H. C. Luong, "A 57.5-90.1-GHz Magnetically Tuned Multimode CMOS VCO," *Solid-State Circuits, IEEE Journal of*, vol. 48, pp. 1851-1861, 2013.
4. Z. Qiong, M. Kaixue, Y. Wanxin, and Y. Kiat Seng, "A low power millimetre-wave VCO in 0.18 μm SiGe BiCMOS technology," in *Circuits and Systems (APCCAS), 2012 IEEE Asia Pacific Conference on*, 2012, pp. 244-247.