

A Wideband Upgrade for the Australia Telescope Compact Array

Dick Ferris ⁽¹⁾, Warwick Wilson ⁽²⁾

⁽¹⁾ *CSIRO Australia Telescope National Facility, PO Box 76, Epping NSW 1710, Australia,
E-mail: Dick.Ferris@csiro.au*

⁽²⁾ *As (1) above, E-mail: Warwick.Wilson@csiro.au*

ABSTRACT

The maximum signal bandwidth on the Australia Telescope Compact Array (ATCA) is to expand from 128MHz to 2GHz. Central to this development is a Field Programmable Gate Array (FPGA)-based digital filterbank correlator featuring high dynamic range and flexible configuration. Associated analog to digital conversion requirements will push the limits of high-speed sampling and quantisation techniques. These new technologies are direct candidates for signal processing on the proposed Square Kilometer Array (SKA). The correlator includes extra ports to incorporate two SKA demonstrator antenna stations into the ATCA, providing both a more powerful instrument and a mature test bed for the demonstrators.

OVERVIEW

The Australia Telescope Compact Array (ATCA) [1] is a connected element aperture synthesis radiotelescope comprising of six 22 meter diameter antennas. The operating frequency range is from 1.2 to 105 GHz. Four signals can be processed simultaneously, each with a maximum bandwidth of 128MHz, where the frequency resolution is 4MHz. A 5-year project has recently been launched to replace the entire backend system of the ATCA. This upgrade will increase the maximum bandwidth on each of the four signals to 2GHz. Central to this development is a Field Programmable Gate Array (FPGA)-based digital filterbank FX correlator featuring high dynamic range and flexible configuration. Associated analog to digital conversion requirements will push the limits of high-speed sampling and quantisation techniques. Eight bit data samples and sixteen bit (minimum) internal signal paths through to the integrators will provide performance approaching analog correlation but with the obvious advantages of digital processing. Combined with excellent channel selectivity the system will be significantly more robust against strong interferers than contemporary 2-bit correlators.

Conversion System

As shown in Fig. 1, the analogue filtering and phase rotated local oscillators and sampling clocks in the current system will be replaced by a very much simpler design with unrotated local oscillators and a single 2GHz bandwidth anti-aliasing filter. All fringe rotation and delay tracking will be moved to the digital filterbanks. Although the high dynamic range of the digital filterbanks will generally allow good rejection of interfering signals, at some frequencies analogue band reject filters may be required to reject very strong interferers.

Sampler/Digitisers

The method of acquiring 2GHz bandwidth data to the required precision will depend on the state of rapidly developing technology. The 4Gbps 8-bit digitisers needed here are not yet commercially available but the 'state of the art' is close. A number of hybrid circuits are under investigation and the correlator design allows ready adaptation to the best solution that emerges during, or after, its construction.

Data Transmission

Single mode fibre optic cables are already in place and will be used for data transmission from antenna to central site. Digitising at the antenna and digital data transmission would take advantage of commercial components being developed for high speed network communications. Alternatively, broadband electro-optical modulators could be used to transmit the 2GHz bandwidth analog signals and so move sampling and quantisation from the antenna to the correlator, thus avoiding self generated interference. The even more attractive option of photonic sampling in the antenna combined with quantisation at the correlator has been demonstrated [2], but may not be practical in our timescale.

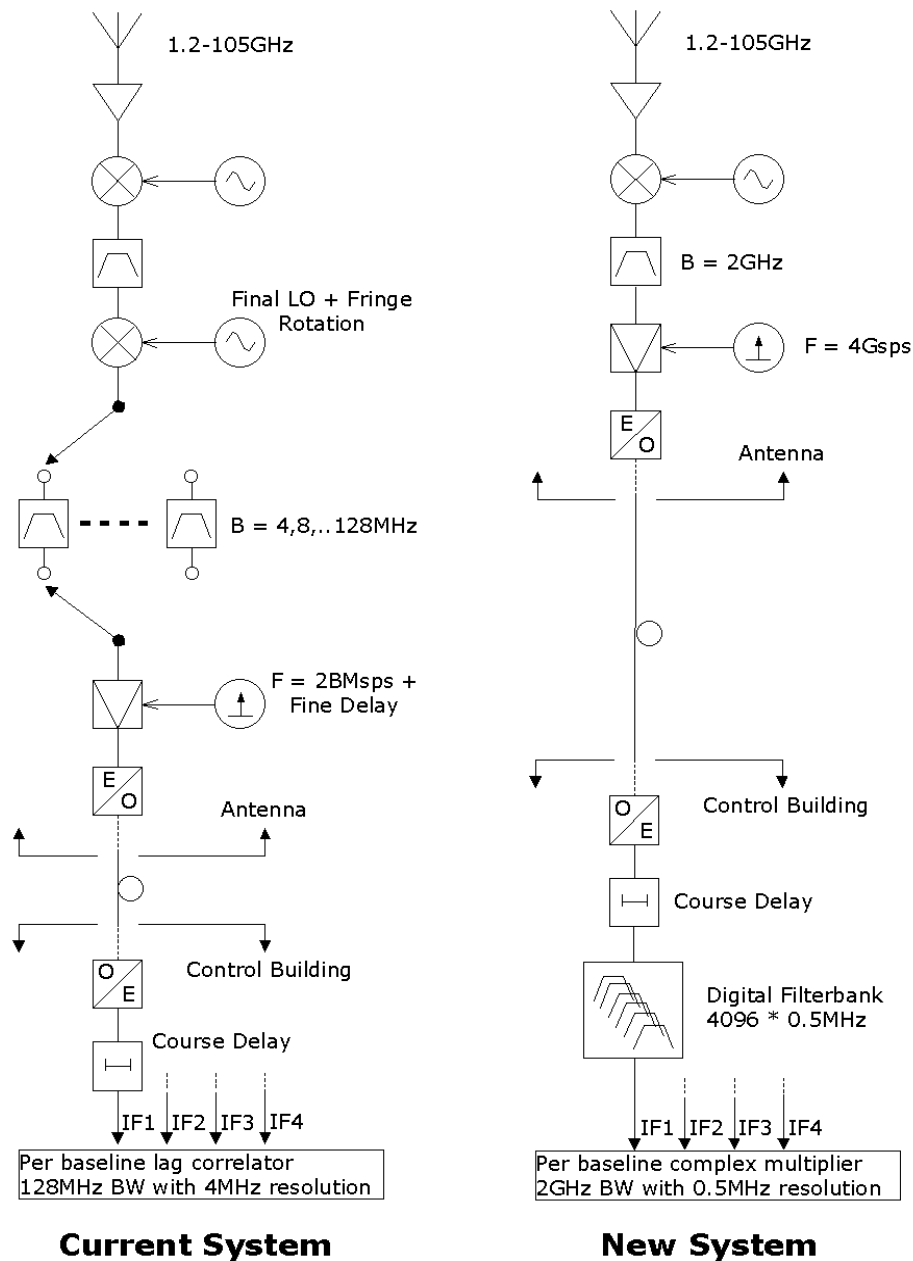

Fig. 1. Upgrade Block Diagrams

Digital Filter Bank FX Correlator

Whereas the 'F' in 'XF correlator' necessarily represents a Fourier transform, the 'F' in 'FX correlator' indicates a filterbank of which the ubiquitous FFT is but one, rather crude, example. Conventional uniform filterbanks comprise an array of quadrature downconverters. For each one the LO frequency defines the centre of the passband, and identical lowpass filters in the I and Q outputs define its shape. Direct implementation of large arrays of order 10^3 channels is expensive in any technology. Fortunately digital converters using FIR output filters can be described with simple algebra, thus providing an alternative form of 'circuit design'. Comparison of the set of expressions for a filterbank reveals many common, i.e. redundant, operations. With a judicious choice of parameters the whole can be factorised and rearranged as a single instantiation of the FIR filter in polyphase form, and a matrix of complex modulators $e^{-j\omega_k t}$ in the form of a DFT [3], [4]. The DFT is naturally evaluated as an FFT.

Fig. 2 shows the resulting structure. Taps of the original FIR filter are distributed amongst the short (length ~ 16) FIR sections p_ρ . All computation is at the output channel rate. Compared with direct implementation, the hardware clock rate is reduced by a factor of $2M$ and the number of filter evaluations is also reduced by $2M$. Modulations are reduced by a factor of approximately $M/\log_2 M$ thanks to the FFT. With M of order 10^3 these represent considerable savings in cost and complexity. The channel shape may be designed with standard filter tools to have a rectangular passband with steep transitions to deep stopbands, in contrast to the compromise of channel smearing and leakage which besets the simple FFT solution. Non-overlapped bands also permit simultaneous high resolution analysis *within* individual channels by small external processors, and high band efficiency offers maximum SNR in the integrated visibilities.

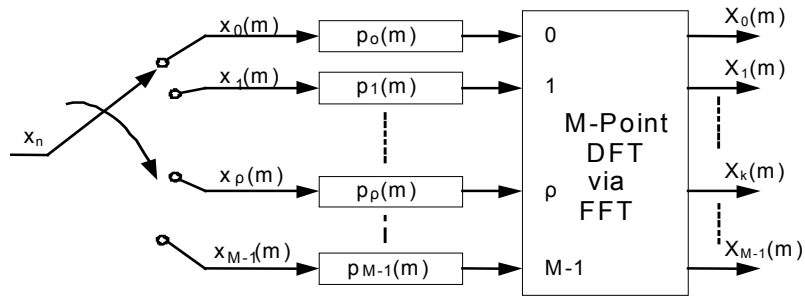

Fig. 2. M-Channel Filterbank in Polyphase Form

Recently released FPGAs have resources which are ideal for FIR filter structures, FFTs and integrating correlators. The use of FPGAs rather than custom chips is economical, and gives an added bonus in the ability to reconfigure the hardware as required to produce instruments with quite different characteristics. Sufficient I/O pins and internal resources are available to support data from high resolution ADCs, and provide a dynamic range of approximately 16 bits at the FFT output. Some initial design work has shown that an implementation of the polyphase filterbank structure for a 2GHz signal bandwidth can provide up to four thousand channels in only four FPGAs.

The combination of a digital filter with a technology capable of storing many sets of coefficients provides an easy method of inter-sample interpolation. Thus ‘fractional sample delay’ for delay tracking amounts to selecting the appropriate coefficient set, and is effectively a ‘free’ feature of the polyphase filter. The fringe rotation function is carried out in an additional FPGA on the channelised data.

The overall structure of the filterbank correlator is shown in Fig. 3. The correlator elements will also be implemented in FPGAs.

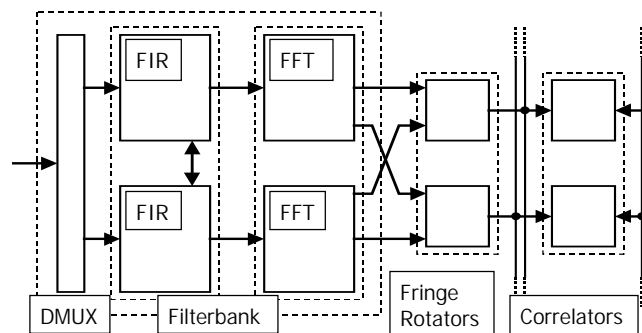

Fig. 3. Basic Filterbank Correlator Structure

Some spectroscopic observations require high resolution across relatively small bandwidths. The FPGA architecture allows the hardware to be completely reconfigured to provide ‘zoom’ modes as illustrated in Fig. 4. The processing first selects one or more small subbands using simple filters, then subjects each of these to filterbank analysis. The resultant ability to observe multiple spectral lines simultaneously is a powerful new capability.

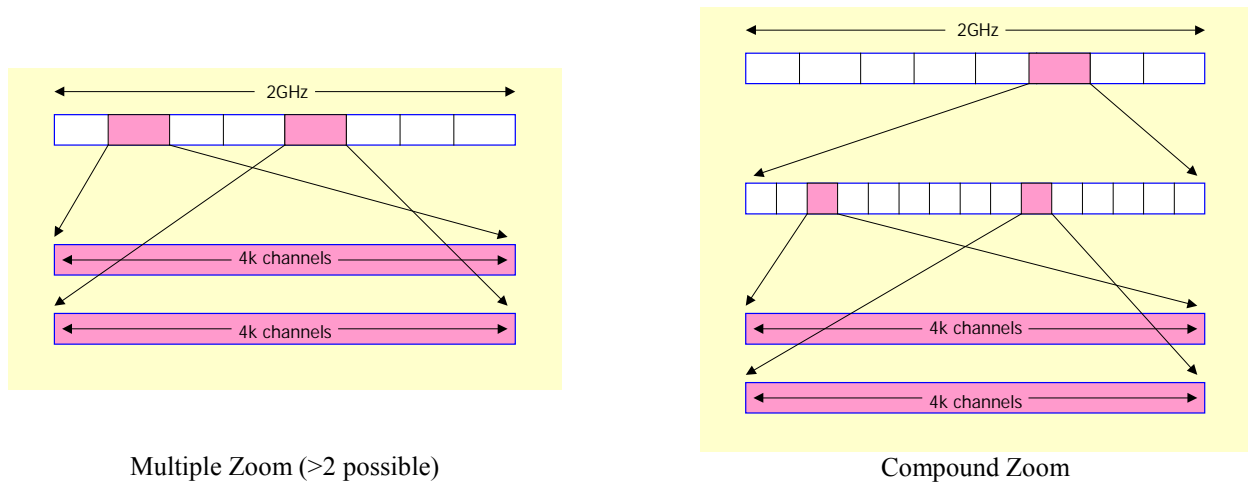

Fig. 4. Digital Filter Bank Zoom Modes

Square Kilometer Array (SKA) Development Role

These new technologies are direct candidates for signal processing on the proposed SKA. The correlator includes extra ports to incorporate two new SKA demonstrator antenna stations into the ATCA, providing both a more powerful instrument and a well-featured test bed for the demonstrators. The extended interferometer structure accommodates the four-beam, single frequency operation of the SKA demonstrators with the single beam, dual frequency operation of the ATCA antennas.

ACKNOWLEDGEMENTS

Funding for the upgrade of the ATCA comes from a Major National Research Facility grant from the Australian Federal Government. We thank John Bunton for discussions and Bruno Stuber for his early work on the detailed design of the digital filter bank.

REFERENCES

- [1] R.H. Frater and J.W. Brooks (Eds.), “The Australia Telescope”, Journal of Electrical and Electronics Engineers, Australia, vol. 12, No. 2, June 1992.
- [2] T.R. Clark, J.U. Kang, and R.D. Esman, “Performance of a Time- and Wavelength-Interleaved Photonic Sampler for Analog-Digital Conversion,” IEEE Phot. Tech. Letters, vol. 11, pp. 1168-1170, September 1999.
- [3] M.G. Bellanger and J.L. Daguét, “TDM-FDM Transmultiplexer: Digital Polyphase and FFT”, IEEE Trans. Commun., Vol. Com-22, No. 9, pp. 1199-1205, September 1974.
- [4] M.G. Bellanger, G. Bonnerot, and M. Coudreuse, “Digital Filtering by Polyphase Network: Application to Sample-Rate Alteration and Filter Banks”, IEEE Trans. Acoust. Speech Signal Process., Vol. ASSP-24, No. 2, pp 109-114, April 1976.